

Central Rally

Aichi/Gifu 2019
7-10 NOVEMBER

Rally Japan 2020 へ向け
いよいよ道が開かれる!



English

**SUPPLEMENTARY
REGULATIONS**



Index

| | | |
|------------|---|----------|
| 1 | Introduction | P3 |
| 2 | Rally Outline and Organisation | P3 – 4 |
| 3 | Programme | P5 – 6 |
| 4 | Entries | P7 – 9 |
| 5 | Insurance | P9 – 10 |
| 6 | Advertising and Identification | P10 |
| 7 | Tyres | P10 |
| 8 | Fuel | P11 |
| 9 | Reconnaissance | P11 |
| 10 | Administrative Checks | P11 – 12 |
| 11 | Scrutineering, Sealing and Marking | P12 – 13 |
| 12 | Other Procedures | P13– 14 |
| 13 | Identification of Officials | P14 |
| 14 | Prizes | P15 |
| 15 | Final Checks and Protests | P15 |
| Appendix 1 | Itinerary | P16 – 17 |
| Appendix 2 | Reconnaissance Schedule | P18 |
| Appendix 3 | Competitors Relations Officer (CRO) | P18 |
| Appendix 4 | Competition Numbers and Advertising | P19 |
| Appendix 5 | Safety Equipment | P20 |
| Appendix 6 | Start Signal Sequences and Start Procedure | P21 |
| Appendix 7 | HQ and Service Park Layout | P22 – 23 |

1 Introduction

1.1 Preamble

This rally will be run in compliance with the FIA International Sporting Code and its appendices, the 2019 FIA Regional Rally Sporting Regulations and these Supplementary Regulations. Any modifications, amendments and/or changes to these Supplementary Regulations will be announced only by numbered and dated Bulletins (issued by the Organiser or the Stewards).

These Supplementary Regulations are prepared in English and in Japanese. In case of any discrepancy the English text will be binding.

The 2019 FIA Regional Rally Sporting Regulations can be found at the FIA website:

www.fia.com/sport/regulations

1.2 Road Surface, Overall SS Distance and Total Distance of the Itinerary

The Special Stages are surfaced in tarmac.

LEG1: 60.06km

LEG2: 68.54km

- SS Distance: 128.60km
- Total Distance: 702.66km
- Number of LEGs: 2
- Number of Sections: 4
- Number of SSs: 14

2 Rally Outline and Organisation

2.1 Competition Status and Rally Outline

| | |
|-----------------|--------------------------------------|
| Status | 2019 FIA International Rally |
| Name | Central Rally Aichi/Gifu 2019 |
| Dates | 7 – 10 November 2019 |
| Location | Aichi Prefecture and Gifu Prefecture |

2.2 Status and Series

2.2.1 International

2.2.2 FIA International Rally

2.2.3 2019 Japan Super Rally Series (non-championship event)
*points scored in this rally will not be included in the JSR season points

2.3 Visa Numbers – FIA and JAF

| | |
|-----|--------------------|
| FIA | VISA No. 1.0004336 |
| JAF | VISA No. 2019-0029 |

2.4 Organisers' Name, Address and Contact Details

Mazda Sports Car Club (MSCC) *JAF authorised club #13014
c/o Kojima Aluminium, 6-24-9 Shimouma, Setagaya Tokyo 154-0002
Phone: +81 (0)3 3414 0176 Fax: +81 (0)3 3414 0472
www.mazdasportscarclub.jp

Toyota Motorsports Club (TMSC) *JAF authorised club #13001
Toyota Kudan Building B1, 2-3-18 Kudanminami, Chiyoda Tokyo 102-0074
Phone: +81 (0)3 3221 9950 Fax: +81 (0)3 3221 9924
<http://toyota-motorsports-club.jp>

NPO MOSCO (MOSCO) *JAF member #10003
96-5 Imai, Tsumagoi, Agatsuma Dist. Gunma 377-1521
Phone: +81 (0)277 20 4633 Fax: +81 (0)278 66 1000
www.n-mosco.com

SAN's Inc. (SANs) *JAF member #13066
Shinjuku Eastside Square 7/F, 6-27-30 Shinjuku, Shinjuku-ku, Tokyo 160-8469
Phone: +81 (0)3 6897 4823 Fax: +81 (0)3 6897 4840
www.sans-inc.net

2.5 Organising Committee

| | |
|-------------|---|
| Chairperson | Masaharu SAKAI (SAN's) |
| Members | Toshinori NISHII (MSCC), Akira ENDO (MSCC), Masanori SEKIYA (TMSC), Nobuhide TACHI (TMSC), Koji TAKAHASHI (SAN's), and Haruo TAKAKUWA (MOSCO) |

2.6 Stewards of the Meeting

| | |
|---------------|--------------------------------------|
| Chief Steward | Indradjit SARDJONO (IDN) |
| Stewards | Sadaaki SHICHITA and Takahisa OGUCHI |

2.7 Senior Officials

| | |
|--|---|
| Clerk of the Course | Sadatoshi ANDO (COC) |
| Deputy Clerk of the Course | Kunio ICHIKAWA (DCOC) |
| Assistant Clerk of the Course, Route | Shigeyuki GOTO |
| Assistant Clerk of the Course, Results | Naoki KUROSAKI |
| Chief Technical Officer | Hajime HOSHINO |
| Competitors Relations Officer | Naoto MARUYAMA |
| Media Officer, National | Masakazu NAGANO (SAN's) |
| Medical Director | Hiroshi TAKAHASHI |
| Chief Medical Officer | Yasushi AOYAMA (surgeon) |
| Medical Officers | Hitoshi ATOMI (surgeon) and Takanori KAMITANI (surgeon) |
| Service Park Coordinator | Jun'ichi FUKUI (SAN's) |
| Regroup Coordinator | Hiroyasu SONODA |
| Secretary General | Mikio HORIGUCHI |
| Secretariat | Koji TAKAHASHI, Yoshiyuki SUNAGA and Hiroki KOBAYASHI (SAN's) |

2.8 Rally HQ

Multipurpose Room 2, Global Centre, Expo Park (Morikoro Park)
1533-1 Otsu, Ibaragabasama, Nagakute, Aichi 480-1342
Phone Morikoro Park office: +81 (0)561 64 1130
Rally HQ: +81 (0)561 61 0880

Open Wednesday 6 November at 9:00

Close Sunday 10 November at 19:00

2.9 Management Office (entries and enquiries)

Rally Japan Management Office (c/o SAN's Inc.)
Shinjuku Eastside Square 7/F, 6-27-30 Shinjuku, Shinjuku-ku, Tokyo 160-8469
Phone: +81 (0)3 6897 4823 Fax: +81 (0)3 6897 4840 E-mail: info@rally-japan.jp
www.rally-japan.jp

3 Programme

3.1 Schedule Before the Rally

Friday 30 August

| | | |
|-------|--|---------|
| 09:00 | Publication of Supplementary Regulations | Website |
|-------|--|---------|

Friday 20 September

| | | |
|-------|-------------------------|-----------------------|
| 09:00 | Opening Date of Entries | Permanent Secretariat |
|-------|-------------------------|-----------------------|

Wednesday 10 October

| | | |
|-------|------------------------------|---------|
| 09:00 | Publication of Rally Guide 2 | Website |
|-------|------------------------------|---------|

Tuesday 15 October

| | | |
|-------|-------------------------------------|-----------------------|
| 09:00 | Opening Date of Media Registrations | Permanent Secretariat |
|-------|-------------------------------------|-----------------------|

Monday 21 October

| | | |
|-------|--------------------------|-----------------------|
| 21:00 | Closing Date for Entries | Permanent Secretariat |
|-------|--------------------------|-----------------------|

Monday 28 October

| | | |
|-------|------------------------------------|---------|
| 21:00 | Publication of Approved Entry List | Website |
|-------|------------------------------------|---------|

Thursday 31 October

| | | |
|-------|--------------------------------------|-----------------------|
| 21:00 | Closing Date for Media Registrations | Permanent Secretariat |
|-------|--------------------------------------|-----------------------|

Friday 1 November

| | | |
|-------|--|-----------------------|
| 09:00 | Issuing of the Road Book and Route Map | Permanent Secretariat |
|-------|--|-----------------------|

3.2 Schedule During the Rally

Wednesday 6 November

| | | |
|---------------|--|-------------------------|
| 09:00 | Opening of Rally Headquarter (HQ) | Rally HQ, Expo Park |
| 10:00 – 15:00 | Test Run | Cycling Road, Expo Park |
| 12:00 | Opening of Official Notice Board | Rally HQ Entrance |
| 15:00 – 19:30 | Administrative Checks & Reconnaissance Registrations #1 Collection of Road Book & Rally Plate | Rally HQ, Expo Park |
| 19:30 | Closing of Rally HQ | Rally HQ, Expo Park |

Thursday 7 November

| | | |
|---------------|--|-------------------------|
| 08:00 | Opening of Rally HQ | Rally HQ, Expo Park |
| 08:00 – 09:00 | Administrative Checks & Reconnaissance Registrations #2 Collection of Road Book & Rally Plate | Rally HQ, Expo Park |
| 08:30 – 19:00 | Reconnaissance #1 | |
| 15:00 – 19:00 | Media Accreditation #1 | Media Centre |
| 16:00 – 19:00 | Registrations of Service #1 | Rally HQ, Expo Park |
| 17:00 – | Opening of Service Park | Service Park, Expo Park |
| 19:30 | Closing of Rally HQ | Rally HQ, Expo Park |

Friday 8 November

| | | |
|---------------|--|---------------------------------|
| 05:00 | Opening of Rally HQ | Rally HQ, Expo Park |
| 07:00 – 11:00 | Registrations of Service #2 | Rally HQ, Expo Park |
| 07:00 – 13:30 | Reconnaissance #2 | |
| 10:00 – 16:00 | Scrutineering | Scrutineering Garage, Expo Park |
| 13:00 – 14:00 | Media Accreditation #2 | Media Centre |
| 14:00 – | Media Briefing | Media Centre |
| 16:00 – 17:00 | Shakedown (for those appointed by the Organiser) | Reverse Short, Expo Park SS |
| 16:30 – | Stewards' Meeting | Stewards Office |
| 16:45 | Publication of Start List | Official Notice Board · Website |
| 17:00 – | Media Conference | Media Centre |
| 17:30 – | Opening Ceremony & Photocall | Expo Park |
| 18:00 – | Ceremonial Start | Expo Park |
| 20:00 | Closing of Rally HQ | Rally HQ, Expo Park |

Saturday 9 November

| | | |
|---------------|------------------------------------|---------------------------------|
| 06:30 | Opening of Rally HQ | Rally HQ, Expo Park |
| 07:30 – | Start of LEG1 | TC0, Expo Park |
| 17:33 – (TBC) | End of LEG1 (Parc Fermé) | Parc Fermé, Expo Park |
| 20:30 | Deadline for Re-start Applications | Rally HQ, Expo Park |
| 20:30 (TBC) | Publication of Start List for LEG2 | Official Notice Board · Website |
| 21:00 | Closing of Rally HQ | Rally HQ, Expo Park |

Sunday 10 November

| | | |
|---------------|---|---------------------------------|
| 04:30 | Opening of Rally HQ | Rally HQ, Expo Park |
| 05:50 – | Start of LEG2 | Parc Fermé, Expo Park |
| 18:04 – (TBC) | Podium Ceremony | Rally Park, Expo Park |
| 18:10 – (TBC) | Final Scrutineering | Scrutineering Garage, Expo Park |
| 19:00 (TBC) | Publication of Provisional Final Classification | Official Notice Board · Website |
| 19:30 (TBC) | Publication of Final Classification | Official Notice Board · Website |
| 21:00 | Closing of Rally HQ | Rally HQ, Expo Park |

4 Entries

4.1 Opening/Closing Date for Entries (JST, GMT+9)

Open Friday 20 September at 9:00

Close Friday 21 October at 21:00

4.2 Entry Procedure

4.2.1 Where to Make an Entry

Rally Japan Management Office (c/o SAN's Inc.)

Phone: +81 (0)3 6897 4823 Fax: +81 (0)3 6897 4840 E-mail: entry@rally-japan.jp

www.rally-japan.jp

4.2.2 Entry Procedure

Those wishing to take part in Central Rally Aichi/Gifu 2019 must register and fill in the entry form along with the documents shown below duly completed and send them to the Management Office via FAX or email before the closing date for entries (no postal mail accepted).

Image data of the driver, co-driver and vehicle to take part in the rally must be emailed before the closing date for entries.

The participant agreement on the entry form must be duly signed and, in conformity with the 2019 FIA Regional Rally Sporting Regulations, the original copy shall arrive at the Organiser within 5 days of the closing date for entries.

The entry will only be accepted if accompanied by the following documents:

- A set of entry forms
- Promotional information
- Entry booklet / a set of application forms
- On-board camera application
- Photocopy of the vehicle inspection certificate (those registered in Japan)
- A Carnet de Passages en Douane from the ASN of which the vehicle is registered in (those temporarily imported to Japan)
- Photocopy of the automobile insurance policy valid for the rally competition or rally insurance application
- Image data of the driver, co-driver and vehicle to take part in
- Participant agreement

4.3 Number of Entries Accepted and Classes

4.3.1 Number of Entries Accepted

The maximum number of entrants will be 90 (including the National Class).

According to the FIA International Sporting Code, Art. 3.14.1, the Organiser reserves the right to refuse entries and notify the applicant of such refusal within 2 days of the closing date for entries.

If more than 90 entries are received the acceptance of entries will be at the sole discretion of the Organiser.

Anyone whose licence has been issued outside Japan must obtain an authorisation from their ASN or an ASN's approval seal (stamp) on their entry form.

4.3.2 Classes

FIA International Rally

Cars eligible to enter this class are those conforming to the 2019 FIA Regional Rally Sporting Regulations, Art. 4 and the 2019 FIA Regional Rally Sporting Regulations V4 (APRC), Art. 4 (incl. those eligible national/regional cars). Classes of cars will be shown on the 2019 FIA Regional Rally Sporting Regulations, Art. 4.

Classification: RC2, RGT, RC3, RC4 and RC5

Japan Super Rally Series (JSR) *non-championship (points scored in this rally are not included in the JSR season points)

4WD Class: Cars complying with 2019 FIA Regional Rally Sporting Regulations, Art. 4; or JSR

2WD Class: Cars complying with 2019 FIA Regional Rally Sporting Regulations, Art. 4; or JSR

Other

Other than those above that conform to the 2019 FIA Rally Sporting Regulations.

4.4 Entry Packages

4.4.1 Entry Fees

All entrants 210,000 JPY (plus tax) per car

Special rate for early registrants* 180,000 JPY (plus tax) per car

* Special rate is applicable to those who completed the entry procedure before 30 September.

4.4.2 Entry Packages

Below are included in an entry package.

| | | | |
|----------------------------------|-----|---------------------------------|--------|
| Reconnaissance Participation Fee | yes | Service Crew Pass | 5 |
| Rally Participation Fee | yes | Guest Pass | 2 |
| Road Book | 2 | Hospitality Lounge Pass | 2 |
| Route Map | 2 | Service Vehicle Pass | 2 |
| Official Programme | 4 | Team Vehicle Parking Permit | 2 |
| Entrant Pass | 2 | Service Park Space at Expo Park | 5m×10m |

Contact the Organiser for additional orders.

4.4.3 Entry to JSR (Japan Super Rally Series)

Entry to JSR can be made by filling in the entry form on the Entry Booklet. JSR in Central Rally Aichi/Gifu 2019 is a non-championship event thus points scored in this rally will not be included in the 2019 JSR series points. While at the same time this is an authorised class in this rally and the top 3 finishers will be entitled to the prizes.

4.4.4 Accommodation

Accommodation can be booked online through the below official hotel agency.

Book online by clicking on the link below:

<https://amarys-jtb.jp/crag2019/>

JTB Business Network Inc., Chubu MICE Centre

Global Gate 8/F, 4-60-12, Hiraike-cho, Nakamura-ku, Nagoya, Aichi, 453-6108 Japan

Phone: +81 (0)52 446 5099

E-mail: cub_mice@jbn.jtb.jp

Business Hours: 10:00 – 17:00 (JST, Mon-Fri)

4.4.5 Test Run

Participants in this rally may take part in a test run held at the cycling road in Expo Park (Morikoro Park) on Wednesday 6 November between 10:00 and 15:00. Participation fee is 30,000JPY (plus tax) per car. Orders must be made along with the Central Rally Aichi/Gifu 2019 entry by filling in the Entry Booklet/Application Form.

4.5 Payment

Entry fees, accommodation and any other fees must be paid by wire transfer to the account below. Please make your payment immediately upon making your entry.

Bank Details

| | |
|-------------------------|--------------------------|
| Name of the Bank | Resona Bank (0010) |
| Branch | Shintoshin Banking Dept. |
| Account No. | 675-3492393 |
| SWIFT Code | DIWAJPJT |
| City/Province | Shinjuku-ku, Tokyo |
| Country | Japan |
| Account Holder | SAN'S INC. |

Payments must be made in Japanese Yen.
Any bank charges shall be borne by the sender.
No cheques accepted.

4.6 Refund

Entry fees will be full refunded in case:

- 1) your entry has not been accepted; or
- 2) the rally has not taken place

* Those who are unable to take part in the rally due to unforeseen circumstances beyond his/her control (provided that his/her ASN gives legitimacy to the non-participation) will receive 50% refund.

5 Insurance

All competition cars registered outside Japan shall carry compulsory third party insurance (*jibaiseiki*) and voluntary bodily injury/property damage insurance that will be effective throughout the event. Within the scope of each provision shown below, the competition cars registered outside Japan and their crew members are covered by the insurance arranged by the Organiser. * All figures are converted at 110JPY into a USD.

5.1 Special Stages

Coverages for Special Stage spectators are as follows.

- 1) Death: up to 100,000,000JPY (equivalent to 953,000USD)
- 2) Hospitalisation: 7,500JPY per day (72USD/day) *Maximum 180 days from the day of the accident
- 3) Outpatient treatment: 5,000JPY per day (47USD/day)

*Maximum 90 days within 180 days from the day of the accident

5.2 Liaison

Coverages for public liability (bodily injury/property damage) on road sections are as follows.

- 1) Death/injury: unlimited
- 2) Property damage: up to 5,000,000JPY (48,000USD) *Accidents on Special Stages will also be covered.
- 3) Passenger: up to 5,000,000JPY (48,000USD)

*Hospitalisation will be covered maximum 180 days from the day of the accident.

*Outpatient treatment will be covered maximum 90 days within 180 days from the day of the accident.

The coverage of the Organiser-arranged insurance will come into effect at the start of LEG1 and cease at the finish or at the moment of retirement or exclusion. Service vehicles, including those bearing official plates issued by the Organiser, will never be considered as official participants of the rally, thus they are not covered under the insurance policy of the rally and will remain sole responsibility of each owner.

5.3 Rally Cars Registered in Japan

All competition vehicles registered in Japan must be covered by voluntary third party insurance valid for the entire rally competition. The insurance must cover at least:

- 1) Death/injury: up to 20,000,000JPY (180,000USD) or over
 - 2) Property damage: 2,000,000 (18,000USD) or over
 - 3) Passenger: 10,000,000JPY (91,000USD) or over
- *JMRC mutual aid system (solatium) can be used for Passenger insurance.

The insurance above can also be arranged by the rally secretariat. Download the application form from the website.

5.4 Insurance for Team Members (except crew)

Coverages for public liability (bodily injury/property damage) on road sections are as follows.

- 1) Death: up to 10,000,000JPY (91,000USD)
- 2) Hospitalisation: 5,000JPY per day (45USD/day) *Maximum 180 days from the day of the accident
- 3) Premium is 550JPY (5USD) per person which is valid for one week.

6 Advertising and Identification

6.1 Windows

Advertising is allowed on the car body including the roof while those on top of the front windscreen is allowed only on the cars registered outside Japan. The advert size must be 10cm or smaller in height from the top edge of the front windscreen, and 8cm or smaller in height from the top edge of the rear windscreen.

6.2 Restrictions

There are no restrictions on advertising, including those of alcoholic beverages and tobacco, to be affixed on the competition cars and team wears.

6.3 Rally Plates and Identification

The Organiser will provide each crew with a set of a rally plate and identification numbers in accordance with the 2019 FIA Regional Rally Sporting Regulations, Art.18 and 19. As detailed on the Appendix 4, they must be affixed to their car in the positions prior to scrutineering and must be visible for the duration of the rally. A fine of 54,000JPY will be imposed on violators.

7 Tyres

7.1 Permitted Tyres

No studded tyres are permitted in this rally.

7.2 Tyre Quantities

No restrictions are placed on the maximum quantity of tyres.

8 Fuel

No leaded petrol are allowed in this event. Levels of lead will be checked in JIS K2255 test.

Competitors may use FIA fuel conforming to the FIA International Sporting Code, Appendix J, Art. 252.9. The FIA fuel shall be arranged by the competitors themselves and bring it to the designated location.

Between the close of scrutineering and the rally finish, refuelling can be done at the designated petrol stations shown on the Road Book.

9 Reconnaissance

- 9.1** Reconnaissance will take place on Thursday 7 and Friday 8 November for competition crew under the Organiser's control.
- 9.2** Reconnaissance registrations open along with administrative checks at Rally HQ on Wednesday 6 November between 15:00 and 19:30, and Thursday 7 November between 8:00 and 9:00. Each crew must receive a "rece card" and a "vehicle identification card" upon completion of registration.
- 9.3** The reconnaissance schedule is shown on the Appendix 2.
- 9.4 Restrictions**
- 9.4.1** Reconnaissance must be performed on a car with no livery.
- 9.4.2** Identification numbers must be affixed to the car during the course of reconnaissance.
- 9.4.3** Crews are authorised to drive a maximum of two passages on each special stage within the given time unless you make it to each stage before closing time. Special stages run twice are considered to be one special stage.
- 9.5 Traffic Rules**
- 9.5.1** During reconnaissance, competitors must comply strictly with the road traffic laws and any further requirements of the Organiser as published on the Supplementary Regulations or in bulletins. At all times, the safety and rights of other road users must be respected. Officials may monitor the behaviour of competitors on the reconnaissance route with visual contact, measuring device, photograph and/or video. All offences will be reported to the Stewards who may impose a maximum penalty of refusal of rally start.
- 9.5.2** Speed limits as signposted on all roads used during reconnaissance must be observed. Failure to comply will result in a penalty to be imposed by the Stewards according to the 2019 FIA Regional Rally Sporting Regulations, Art. 20.2.
- 9.6 Tyres**
Road-homologated series production tyres for asphalt must be used for reconnaissance.

10 Administrative Checks

10.1 Documents to be Presented

At administrative checks, the following documents will be checked and entry form details verified:

- 1) Driver's & co-driver's driving licences and competition licences
* Foreign drivers & co-drivers shall have valid driving licences (International Driving Permits) to drive on public roads in Japan.
- 2) Competitor/entrant licence
- 3) Medical certificate for FIA International Rally participants
- 4) Authorisation for foreign drivers by their ASN to take part in this rally
- 5) Vehicle inspection certificate, compulsory third party insurance policy, and automobile insurance policy valid for this rally
- 6) A Carnet de Passages en Douane issued by ASN of which the vehicle is registered in
*No vehicles imported in other ways than the above (such as ATA carnet) may take part in this rally.

10.2 Timetable

Administrative checks will take place at the Rally HQ on Wednesday 6 November between 15:00 and 19:30, and Thursday 7 November between 8:00 and 9:00.

11 Scrutineering, Sealing and Marking

11.1 Scrutineering Venue and Timetable

Venue Scrutineering Garage in Expo Park

Date Friday 8 November between 10:00 and 16:00

Marking of gearboxes and differentials (incl. spare ones) for all cars, and sealing of turbocharger for turbocharged cars will be performed at scrutineering in accordance with the communication schedule that will be issued before 8 November 2019.

11.2 Mud Flaps

Competition cars may be equipped with mud flaps in conformity to the FIA International Sporting Code, Appendix J, Art. 252.7.7.

11.3 Windows/Nets

The use of silvered or tinted films on the side and on the rear window is authorised in accordance with the FIA International Sporting Code, Appendix J, Art. 253.11.

11.4 Crew's Safety Equipment

All crew must come with homologated crash helmet, racing overall, underwear, gloves, shoes, balaclava and FHR (such as HANS). All those equipment must be presented for scrutineering to be checked for compliance with the FIA International Sporting Code, Appendix L, Chapter III.

11.5 Noise Level

Temporarily imported cars must comply with the noise level regulations of the country which the car is registered in. Cars registered in Japan must be compliant with the Road Transport Vehicle Act, Art. 3.

11.6 National Requirements

Those wishing to use two-way radios must complete the application form on the Entry Booklet to be submitted to the Management Office by 7 September.

11.7 Emergency Stop Switch (Kill Switch)

All competition cars on the International Class must be equipped with an emergency stop (kill) switch that complies with the FIA International Sporting Code, Appendix J, Art. 253.13.

11.8 Fire Extinguisher

All cars must be equipped with an extinguishing system in compliance with the FIA International Sporting Code, Appendix J, Art. 253.7.

11.9 Special Requirements

Each competition car must carry two red reflective triangles, flare, red beacon, tow rope, first aid kit, and a red "SOS" sign and on the reverse a green "OK" board in A3 format, all of which must be kept within easy reach.

11.10 Safety Tracking Equipment

All competition cars taking part in Central Rally Aichi/Gifu 2019 must be equipped with a RallySafe safety tracking (GPS) system. All competitors must make provision in their cars for the installation of the system. Installation and operating instructions are available at www.rallysafe.com.au. The correct functioning and installation of the system will be checked at scrutineering.

RallySafe components consist of a main unit (monitor) and an antenna kit including antenna, brackets and cables. The main unit will be rented at the time of scrutineering while the antenna kit shall be arranged by the competitors themselves. The kit is available for purchase at:

- **RallySafe online shop** <<http://rallysafe.com.au/>>
175.00 - 185.00AUD (plus shipping & import duties)
- **TERZOMARUMURA LLC.** <<https://terzo.thebase.in/items/19278460>>
25,000JPY (plus tax)

The RallySafe main unit shall basically be collected at the entry of the final Parc Fermé. Remove the unit from the car at the final service and return it to a RallySafe staff at the Parc Fermé. In case you are unable to return the unit at the Parc Fermé due to retirement or any other incident, get it back to the rally secretariat at the HQ no later than Sunday 10 November at 19:00. Failure to do so may result in a return by international mail/courier at your own expense.

11.11 On-board Cameras

The entrant of any car which carries an on-board camera must make a prior application at the same time as your rally entry. Whether the camera is installed inside or out of the car, you are required to have it properly installed by the time of scrutineering. Authorised cameras will be identified by an adhesive decal. No unauthorised shooting allowed. All rights of the on-board camera footage are reserved by the Organiser and consequently the Organiser may demand submission of any such footage.

12 Other Procedures

12.1 Opening Ceremony and Photocall

The opening ceremony and photocall take place at Expo Park on Friday 8 November at 17:30 which are mandatory for all crew. No drivers briefings will be held in this rally.

12.2 Ceremonial Start

The ceremonial start held on Friday 8 November at 18:00 is mandatory for all crew. The drivers and co-drivers must wear racing suits and perform the ceremonial start in accordance with instructions from rally officials. A detailed schedule will be published in a communication.

12.3 Start

12.3.1 Start order for the rally will be given on the Official Notice Board.

Publication of the LEG1 Start List Friday 8 November 16:45

Publication of the LEG2 Start List Saturday 9 November 20:30 (TBC)

12.3.2 As on the Start List, the interval between competitors selected by the Organiser will be two minutes while all others will be one minute.

12.4 Official Time used during the Rally

12.4.1 The official time during the rally will be JST (9 hours ahead of GMT).

12.4.2 Crews are authorised to check in before the due time without incurring any penalty at LEG1 TC6C and LEG 2 TC14A, whereas late arrival will incur a penalty.

12.5 Special Stages

12.5.1 The cars' times will be recorded to the 1/10th of a second.

12.5.2 The start and other signals will be given by an electronic digital countdown system. Details are shown on the Appendix 6.

12.5.3 SS3 & SS4 on LEG1 and SS10 & SS11 on LEG2 will be Super Special Stages conforming to the 2019 FIA Regional Rally Sporting Regulations, Art. 41. DNF will incur a penalty.

12.6 Restart after Retirement (Rally 2)

12.6.1 Any crew who has withdrawn from LEG1 may restart the next LEG as Rally 2 under condition of submitting "Rally 2 Application" to the Clerk of the Course no later than Saturday 9 November at 20:30.

12.6.2 Those availing of Rally 2 must present re-scrutineering sheet to the Chief Technical Officer to have their car re-scrutineered at least 60 minutes prior to the car's start time of LEG2. Authorisation will be given only to those who have passed re-scrutineering.

12.6.3 Rally 2 competitors will be included in the Final Classification with a 60-minute penalty.

12.6.4 Rally 2 cars' times on Special Stages will be recorded and officially published.

12.7 Podium Ceremony

The podium ceremony takes place at Expo Park on Sunday 10 November at around 18:04. Top three finishers in each class will claim a podium for a provisional prize-giving. All others are asked to pass through the podium.

13 Identification of Officials

The Post Chiefs and officials will be identified as follows:

| | |
|---------------------------------------|---------------------------------|
| Special Stage Commander | Green tabard with yellow text |
| Post Chiefs | Blue tabard with white text |
| Post Officials | Orange tabard with white text |
| Safety Officials | Red tabard with white text |
| SOS Radio Officials | Yellow tabard with black symbol |
| Medical | Green tabard with white text |
| Stewards | Black tabard with yellow text |
| Competitors' Relations Officer | Yellow tabard with black text |
| Other Officials | Official IDs |

14 Prizes

The prize-giving ceremony takes place as in "12.8" where the following prizes will be given.

14.1 FIA International Rally

- Overall JAF trophy & a supplementary prize will be given to the 1st, 2nd and 3rd finishers
- Each class JAF trophy & a supplementary prize will be given to the 1st, 2nd and 3rd finishers

14.2 Japan Super Rally Series

- Overall JAF trophy & a supplementary prize will be given to the 1st, 2nd and 3rd finishers
- Production JAF trophy & a supplementary prize will be given to the 1st, 2nd and 3rd finishers
- 2WD JAF trophy & a supplementary prize will be given to the 1st, 2nd and 3rd finishers

14.3 Other Class

- Overall JAF trophy & a supplementary prize will be given to the 1st, 2nd and 3rd finishers

15 Final Checks and Protests

15.1 Final Checks

Post event scrutineering takes place on Sunday 10 November at 18:10 at scrutineering garage in Expo Park (TBC).

Cars subject to final checks (decision and notification by the Stewards) must have one representative of the entrant as well as mechanics present at the final checks.

15.2 Protest Fees

The protest fee against FIA is 1,000EUR.

If a protest requires the dismantling and re-assembly of a clearly defined part of the car, the claimant must pay an additional deposit of 54,000JPY.

All protests and/or appeals must be lodged in accordance with the 2019 FIA Regional Rally Sporting Regulations, Art. 55.

15.3 Appeal Deposit

The international appeal deposit against FIA is 3,000EUR.

Appendix 1 | Itinerary

Central Rally Aichi / Gifu 2019 ITINERARY (ver. 3.1)

25 October 2019

| Start LEG1 (Section 1, 2) | | Saturday, 9 November 2019 (Sunrise 6:20, Sunset 16:50 in Nagakute City) | | | | |
|--|--|---|-----------------|-----------------|---------------|----------------|
| TC | LOCATION | SS dist. | Liaison dist. | Total dist. | Target time | First car due |
| 0 | Start - (Expo Park) | | | | | 7:30 |
| RZ 1 | Refuel - Petrol Station (Fujioka SS COSMO) Distance to next refuel | (30.03) | (92.25) | (122.28) | (0:20) | (7:50) |
| 1 | Miyazaki | | 58.45 | 58.45 | 1:15 | 8:45 |
| SS1 | Nukata 1 | 13.58 | – | – | – | 8:48 |
| 2 | Mikawako | | 12.17 | 25.75 | 0:40 | 9:28 |
| SS2 | Mikawako 1 | 14.95 | – | – | – | 9:31 |
| 3 | Okazaki C Park | | 29.08 | 44.03 | 1:10 | 10:41 |
| SS3 | Okazaki 1 | 1.50 | – | – | – | 10:44 |
| RZ 2 | Refuel - Petrol Station (Usami Okazaki IC SS) Distance to next refuel | (0.00) | (4.76) | (6.26) | (0:12) | (10:56) |
| 3A | Expo Park Regroup & Technical Zone IN | | 48.09 | 49.59 | 1:10 | 11:54 |
| 3B | Expo Park Regroup & Technical Zone OUT / Service IN | – | – | – | 0:10 | 12:04 |
| Service A (Expo Park) | | (30.03) | (147.79) | (177.82) | 0:30 | |
| 3C | Service OUT | – | – | – | – | 12:34 |
| RZ 3 | Refuel - Petrol Station (Usami Okazaki IC SS) Distance to Finish | (30.03) | (35.66) | (35.66) | (0:49) | (13:23) |
| 4 | Okazaki C Park | | 40.94 | 40.94 | 1:00 | 13:34 |
| SS4 | Okazaki 2 | 1.50 | – | – | – | 13:37 |
| 5 | Miyazaki | | 20.43 | 21.93 | 0:40 | 14:17 |
| SS5 | Nukata 2 | 13.58 | – | – | – | 14:20 |
| 6 | Mikawako | | 12.17 | 25.75 | 0:40 | 15:00 |
| SS6 | Mikawako 2 | 14.95 | – | – | – | 15:03 |
| 6A | Technical Zone IN | | 52.53 | 67.48 | 1:35 | 16:38 |
| 6B | Technical Zone OUT - Flexi Service IN | – | – | – | 0:10 | 16:48 |
| Flexi Service B (Expo Park) | | (30.03) | (126.07) | (156.10) | 0:45 | |
| 6C | Flexi Service OUT - Parc Fermé IN | – | – | – | – | 17:33 |
| For all cars, (except re-starting crew), (Early check in allowed) TC6C will close at - | | | | | | 21:00 |
| Saturday totals | | 60.06 | 273.86 | 333.92 | | |

Section 1

Section 2

| Re-Start LEG2 (Section 3, 4) | | Sunday, 10 November 2019 (Sunrise 6:21, Sunset 16:50 in Nagakute City) | | | | |
|------------------------------|---|--|-----------------|-----------------|-------------|---------------|
| TC | LOCATION | SS dist. | Liaison dist. | Total dist. | Target time | First car due |
| 6D | Parc Fermé OUT / Service IN | – | – | – | – | 5:50 |
| Service C (Expo Park) | | – | – | – | 0:15 | |
| 6E | Service OUT | – | – | – | – | 6:05 |
| RZ 4 | Refuel - Petrol Station (Touji Kan Mae SS ENEOS) Distance to next refuel | (33.13) | (97.66) | (130.79) | (0:05) | (6:10) |
| 7 | Akechi | | 48.87 | 48.87 | 1:25 | 7:30 |
| SS7 | Akechi 1 | 3.86 | – | – | – | 7:33 |
| 8 | Danto | | 32.04 | 35.90 | 1:00 | 8:33 |
| SS8 | Inabu 1 | 14.76 | – | – | – | 8:36 |
| 9 | Nagura | | 7.65 | 22.41 | 0:30 | 9:06 |
| SS9 | Shitara 1 | 14.51 | – | – | – | 9:09 |
| RZ 5 | Refuel - Petrol Station (Inabu SS ENEOS) Distance to next refuel | (6.14) | (11.49) | (26.00) | (0:38) | (9:47) |
| 10 | Morikoro | | 61.23 | 75.74 | 2:05 | 11:14 |
| SS10 | Expo Short 1 | 1.14 | – | – | – | 11:17 |
| 10A | Expo Park Regroup & Technical Zone IN | | 1.26 | 2.40 | 0:05 | 11:22 |
| 10B | Expo Park Regroup & Technical Zone OUT / Service IN | – | – | – | 0:10 | 11:32 |
| Service D (Expo Park) | | (34.27) | (151.05) | (185.32) | 0:45 | |
| 10C | Service OUT | – | – | – | – | 12:17 |
| 11 | Morikoro | | 0.76 | 0.76 | 0:05 | 12:22 |
| SS11 | Expo Short 2 | 1.14 | – | – | – | 12:25 |
| 12 | Akechi | | 49.99 | 51.13 | 1:20 | 13:45 |
| SS12 | Akechi 2 | 3.86 | – | – | – | 13:48 |
| RZ 6 | Refuel - Petrol Station (Inabu SS ENEOS) Distance to Finish | (29.27) | (24.55) | (28.41) | (0:55) | (14:43) |
| 13 | Danto | | 32.04 | 35.90 | 1:10 | 14:58 |
| SS13 | Inabu 2 | 14.76 | – | – | – | 15:01 |
| 14 | Nagura | | 7.65 | 22.41 | 0:30 | 15:31 |
| SS14 | Shitara 2 | 14.51 | – | – | – | 15:34 |
| 14A | Expo Park Podium Holding IN | | 58.71 | 73.22 | 2:00 | 17:34 |
| | Expo Park Podium Ceremony | – | – | – | 0:30 | 18:04 |
| Sunday totals | | 68.54 | 300.20 | 368.74 | | |

Section 3

Section 4

| Totals of the Rally | | SS | Liaison | Total | % |
|---------------------|-------------|---------------|---------------|---------------|-------------|
| Saturday | 6SS | 60.06 | 273.86 | 333.92 | 18.0 |
| Sunday | 8SS | 68.54 | 300.20 | 368.74 | 18.6 |
| Total | 14SS | 128.60 | 574.06 | 702.66 | 18.3 |

Appendix 2 | Reconnaissance Schedule

Thursday 7 November

| SS Opens | SS | SS No. | No. of Passages Authorized to Drive |
|---------------|----------|-----------|-------------------------------------|
| 9:00 – 10:30 | Okazaki | SS3/SS4 | 2 |
| 10:00 – 12:30 | Nukata | SS1/SS5 | 2 |
| 12:00 – 14:00 | Mikawako | SS2/SS6 | 2 |
| 14:00 – 16:30 | Shitara | SS9/SS14 | 2 |
| 17:30 – 19:00 | Expo | SS10/SS11 | 2 |

Friday 8 November

| SS Opens | SS | SS No. | No. of Passages Authorized to Drive |
|--------------|--------|----------|-------------------------------------|
| 8:00 – 9:30 | Akechi | SS7/SS12 | 2 |
| 9:00 – 12:00 | Inabu | SS8/SS13 | 2 |

Appendix 3 | Competitors Relations Officer (CRO)



Naoto MARUYAMA

Japanese English

Phone: TBA

CRO's Schedule

Friday 8 November

10:00 – 16:00 Scrutineering Garage

Saturday 9 November

7:30 – 9:05 Start Area (TC0)
 11:54 – 13:00 Service Area (TC3A), Expo Park
 16:38 – 17:40 Service Area (TC6A), Expo Park

Sunday 10 November

5:50 – 6:30 Parc Fermé (TC6D), Expo Park
 11:20 – 12:30 Service Area (TC10A), Expo Park
 17:30 – 18:30 Finish Area, Expo Park

Appendix 4 | Competition Numbers and Advertising

Competition numbers, advertising and driver's & co-driver's names shall be properly affixed on the car in conformity with the 2019 FIA Regional Rally Sporting Regulations, Art. 18 and 19. No roof plate will be supplied in this rally.

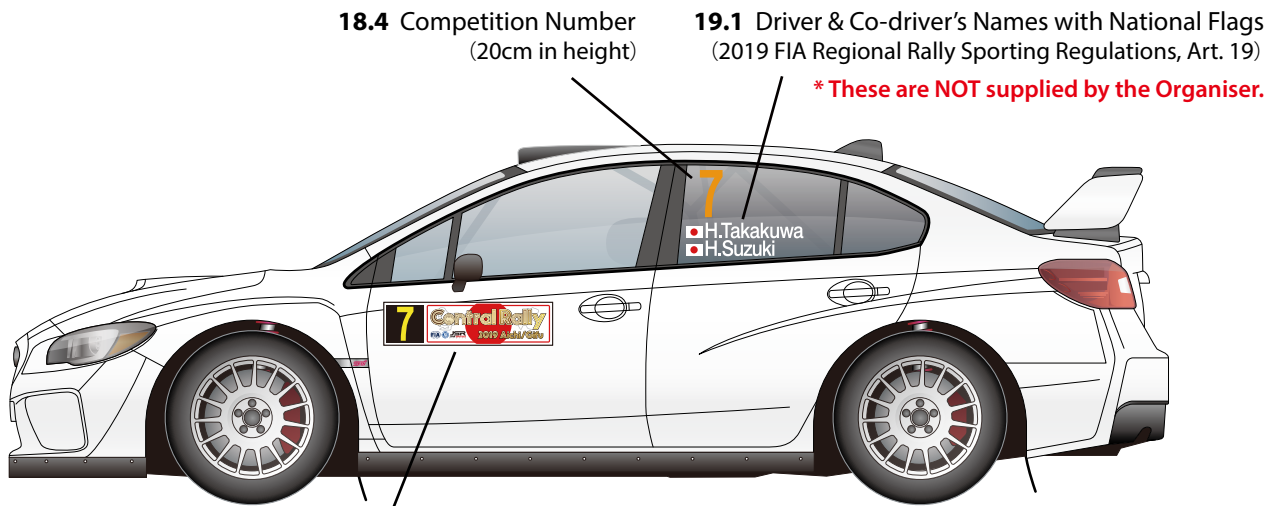
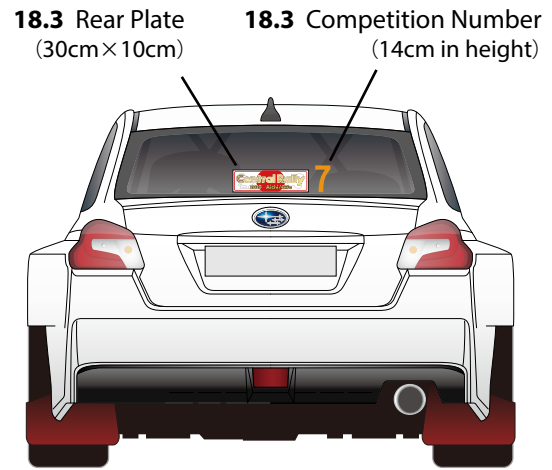
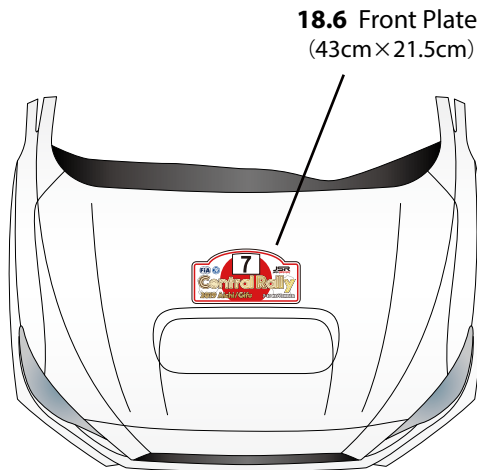

18.2 Front Door Panel (67cm×17cm)

It must be placed in the direction parallel to the window frame with the number at the front. Allow 7-10 cm space between the bottom edge of the frame and the top edge of the panel.

Appendix 5 | Safety Equipment

Competitors are required to read and understand changes and modifications made to the FIA International Sporting Code, Appendix L, Chapter III "DRIVERS' EQUIPMENT".

- 1 Helmets
 - 1.1 Recognised standard
 - 1.2 Frontal Head Restraint system (FHR)
 - 1.3 Conditions of use
 - 1.4 Modifications
 - 1.5 Maximum weight
 - 1.6 Decoration
- 2 Flame-resistant Clothing
- 3 Frontal Head Restraint System (FHR)
 - 3.1 Recognised standard
 - 3.2 Conditions of use
 - 3.3 Compatibility and permitted use of items approved to the FIA 8858-2002, 8858-2010, 8860-2004 and 8860-2010 standards.
- 4 Safety Belts

Appendix 6 | Start Signal Sequences and Start Procedure

- 1**

Five red lights are on 5 seconds prior to the start.
- 2**

Four red lights are on 4 seconds prior to the start.
- 3**

Three red lights are on 3 seconds prior to the start.
- 4**

Two red lights are on 2 seconds prior to the start.
- 5**

One red light is on 1 second prior to the start.
- 6**

All the red lights are extinguished and one **GREEN** light is on to signal the start of the rally.

- In case a false start is detected, i.e. car passes the start line before the green light is given, the signals are **FLASHING**.
- In the event of the system failure, the start procedure will be performed manually by the start marshal's countdown aloud on a 30-15-10-5-4-3-2-1 sec basis.
- Start signals in SS11 and 12 may differ from those above.

Appendix 7 | HQ and Service Park Layout

